

**INSTALLATION**

**756A PBX**

<b>CONTENTS</b>	<b>PAGE</b>	<b>CONTENTS</b>	<b>PAGE</b>
<b>1. GENERAL . . . . .</b>	<b>1</b>	<b>F. Placing Batteries in Battery Module . . . . .</b>	<b>21</b>
<b>2. APPARATUS . . . . .</b>	<b>2</b>	<b>G. Station Equipment . . . . .</b>	<b>21</b>
<b>A. Tools and Test Equipment . . . . .</b>	<b>2</b>	<b>H. Miscellaneous Equipment . . . . .</b>	<b>22</b>
<b>B. Material . . . . .</b>	<b>2</b>	<b>5. PLACING IN SERVICE . . . . .</b>	<b>23</b>
<b>3. PREPARATION . . . . .</b>	<b>2</b>	<b>A. General . . . . .</b>	<b>23</b>
<b>A. Planning . . . . .</b>	<b>2</b>	<b>B. Power Supply . . . . .</b>	<b>23</b>
<b>PBX Floor Space Requirements . . . . .</b>	<b>2</b>	<b>C. Station Lines . . . . .</b>	<b>23</b>
<b>Location of PBX Equipment . . . . .</b>	<b>3</b>	<b>D. Two-Way Central Office Trunks . . . . .</b>	<b>25</b>
<b>Location of Attendant Equipment and Telephone Sets . . . . .</b>	<b>3</b>	<b>E. Attendant Trunks . . . . .</b>	<b>27</b>
<b>Location of Cross-Connecting Terminals . . . . .</b>	<b>4</b>	<b>F. Tie Trunks . . . . .</b>	<b>27</b>
<b>Commercial Power Wiring . . . . .</b>	<b>4</b>	<b>G. Dial Pulse Register . . . . .</b>	<b>27</b>
<b>Cabling and Wiring . . . . .</b>	<b>4</b>	<b>H. Central Office Alarm . . . . .</b>	<b>28</b>
<b>B. Transporting PBX . . . . .</b>	<b>4</b>	<b>I. Night Connections . . . . .</b>	<b>28</b>
<b>4. REQUIREMENTS AND METHODS . . . . .</b>	<b>4</b>	<b>J. Traffic Registers . . . . .</b>	<b>28</b>
<b>A. Unpacking PBX Equipment . . . . .</b>	<b>4</b>	<b>6. FINAL TESTS AND INSPECTIONS . . . . .</b>	<b>29</b>
<b>B. Placing PBX . . . . .</b>	<b>4</b>	<b>1. GENERAL</b>	
<b>C. Placing Cross-Connecting Terminals . . . . .</b>	<b>7</b>	<b>1.01</b> This section covers the general requirements and methods to be followed in the preparation and installation of the 756A PBX.	
<b>D. Placing Attendant Equipment . . . . .</b>	<b>7</b>	<b>1.02</b> This section is reissued for the following reasons:	
<b>E. Cabling and Wiring . . . . .</b>	<b>10</b>	(a) To include the use of even count cable.	
<b>PBX to Cross-Connecting Terminal . . . . .</b>	<b>10</b>	(b) To remove the list of schematic drawings as they are covered by the equipment diagram and the connecting circuit information on the circuit descriptions furnished with the PBX.	
<b>Attendant Equipment to Cross-Connecting Terminal . . . . .</b>	<b>10</b>	(c) To show a typical arrangement for the termination of the 700-type attendant equipment using connecting blocks.	
<b>Multiple Attendant Positions . . . . .</b>	<b>20</b>		
<b>Lettering and Numbering . . . . .</b>	<b>20</b>		
<b>Grounding . . . . .</b>	<b>21</b>		

## SECTION B556.201

- (d) To include a typical arrangement for termination of the new 600-type attendant equipment.
- (e) To remove the information on installation of the 556A PBX which is now covered in Section B523.601.
- (f) To remove information on the J86464 power plant which is now covered in Section B301.866.

Since this reissue covers a general revision, arrows ordinarily used to indicate changes have been omitted.

- 1.03** For a detailed description of the 756A PBX see Section 991.301.01.
- 1.04** Throughout this section common work operations such as cabling, wiring, mounting of equipment, etc, should be performed in accordance with the Bell System Practices applicable.
- 1.05** A set of schematics and circuit description sheets is furnished with the PBX. Drawings for optional equipment that may be used with the 756A PBX, such as the 3A code call unit and the recorded telephone dictation trunk, must be ordered separately.

## 2. APPARATUS

### A. Tools and Test Equipment

- 2.01** In addition to the tools provided with the PBX and the standard tools required for PBX installation work the following tools and test equipment or their equivalent are required:

KS-14510 list 1 volt-ohm-milliammeter

R-1257 adjustable bench level

R-2384 30-inch pinch bar

1/2-inch offset box wrench (J. H. Williams and Co. No. 8725) for bolting modules together.

19/32-inch wrench — For removing nut holding "L" shaped steel bracket attached to top front end of each slide.

### B. Material

- 2.02** Any material which might be required for protecting the customer's premises or PBX during installation.
- 2.03** Petrolatum, for protection of the hands, if handling of batteries is necessary.
- 2.04** The following touch-up colors are to be used when necessary:
  - (a) *No. 10635 satin gloss enamel — Martin Senour Paint Co., Chicago, Ill.:* For the exposed surfaces of the end panels of the cabinet, and the panel of the slide units.
  - (b) *Newark Varnish Works, Newark, New Jersey No. 1848 gray lacquer:* For the exposed surfaces of the top cover, rear panels, and framework of the cabinet.

## 3. PREPARATION

### A. Planning

#### PBX Floor Space Requirements

- 3.01** The floor space requirements for the basic PBX modules, the optional battery module, and the required maintenance space are shown in Fig. 1.

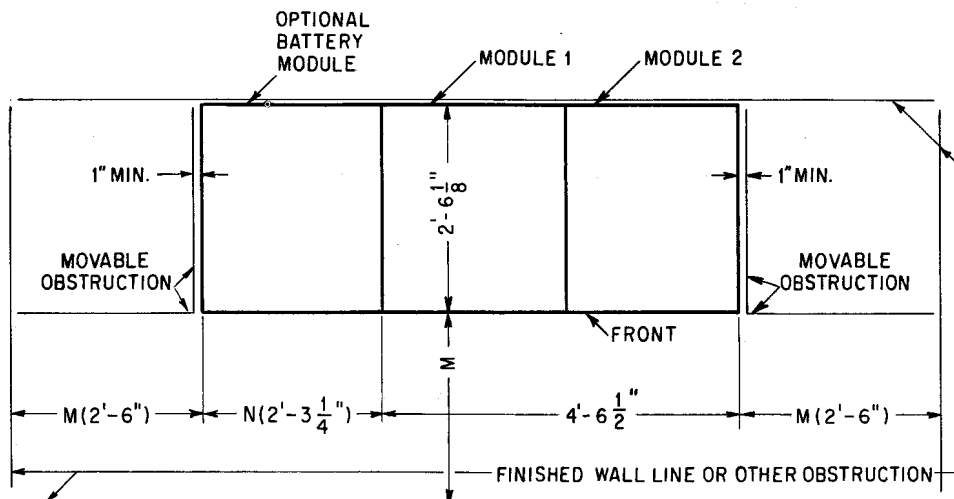

- NOTES: 1. DIMENSION M IS AREA NEEDED DURING MAINTENANCE VISITS AND SHOULD NOT BE LESS THAN 2'-6".
2. DIMENSION N WILL BE ZERO UNLESS BATTERY MODULE IS FURNISHED IN WHICH CASE  $N = 2'-3\frac{1}{4}"$ .
3. HEIGHT  $5'-3\frac{5}{8}"$ , WITH TOP FULLY OPENED  $7'-8\frac{1}{2}"$ .

**Fig. 1 — Floor Space Requirements for 756A PBX**

#### Location of PBX Equipment

**3.02** Inspect the location and surrounding area in which the customer desires the PBX equipment.

**3.03** The location should meet the following general requirements.

- (a) Floor strong enough to support the PBX.
  - (1) The basic PBX weighs approximately 1600 pounds.
  - (2) The PBX with battery reserve cabinet weighs 2500 pounds.
  - (3) The floor should be able to support a load of approximately 160 pounds per square foot.
- (b) Accessible without difficulty.
- (c) Dry and reasonably clean.
- (d) Reasonably well lighted.
- (e) Adequate ventilation.

**3.04** Avoid a location:

- (a) Near windows, skylights, etc, where rain might enter.

- (b) Near sweating water pipes, steam pipes, sprinkler systems, etc.
- (c) Subject to extreme heat or cold.
- (d) Near a hoist, stairway, trap door, pit, moving machinery, etc.
- (e) In passageways used by trucks or other locations where traffic is heavy.
- (f) Where oil mist from machinery, dust, corrosive fumes, exhaust from steam vents, etc, are present.
- (g) Subject to excessive vibration due to operation of machinery or other causes.

#### Location of Attendant Equipment and Telephone Sets

**3.05** If necessary, assist the customer in selecting a location for the attendant equipment or switchboard.

**Note:** To assure proper brilliance of station and trunk lamps of attendant equipment the loop resistance of the lamp leads must not exceed 100 ohms.

## SECTION B556.201

**3.06** Assist the customer in selecting locations for regular station telephone sets, those used for night connections, and those used for automatic transfer of trunks in the event of a power failure.

### Location of Cross-Connecting Terminals

**3.07** Binding post chambers or connecting blocks located in a suitable cross-connecting terminal or house terminal should be used to terminate cables from the PBX.

**3.08** Select a location for the PBX cross-connecting terminal as near as possible to the PBX and which generally meets the requirements in 3.03 and 3.04.

### Commercial Power Wiring

**3.09** The customer should provide commercial power wiring and supply 105-125 volts, 60-cycle ac, single-phase service as follows:

- (a) On a separate 15-ampere fuse.
- (b) Not controlled by a switch.
- (c) 3-wire with third wire grounded in distribution cabinet.
- (d) Hubbell No. 5261 (3-wire) or equivalent receptacle.
- (e) The receptacle should be located adjacent to module 1 and in a position readily accessible for removal of plug for maintenance purposes. The location selected should be such as to prevent accidental removal of the power cord plug. Where local regulations permit, an ES-528772 cord clamp bracket together with a Tinnerman cord clamp of proper size may be used to prevent accidental removal of the power cord plug.

### Cabling and Wiring

**3.10** Discuss with the customer the proposed route and methods of attaching cables and wiring to building walls, baseboards, etc.

**3.11** Permission should be obtained from the property owner or his agent when it is necessary to make attachments to surfaces such as wood panels, glazed tile, marble, etc.

**3.12** When conduit for installation is to be provided, close cooperation is required with the customer or his agent in order that conduits of suitable size and location will be installed.

### B. Transporting PBX

**3.13** Clearance for bringing the PBX modules through doorways, passageways, etc is essential. Each module in its shipping container measures 5 feet in height and is 3 feet 6 inches square at the base.

**3.14** Each PBX module weighs approximately 900 pounds packed in shipping containers. Preparations should be made for transporting the PBX to its location.

**3.15** The PBX modules are packed and shipped in their normal upright position, bolted to a skidded platform. Metal details are applied to the top front of each slide to prevent accidental dislodgment during shipping or unpacking.

**3.16** To avoid damage to the equipment, handle the PBX in the packing case whenever possible.

**3.17** Every precaution should be taken to prevent personal injury or property damage while handling the equipment.

**3.18** To avoid personal injury and property damage use a roller or dolly or similar device, preferably equipped with pneumatic tires, to move the PBX.

**3.19** When moving the PBX with a dolly or hand truck equipped with hard surfaced treads, care must be used to prevent damage to floors or floor coverings. The use of wooden planks or other material will aid in moving the PBX on carpeting, rubber tiling, finished floors, etc.

## 4. REQUIREMENTS AND METHODS

### A. Unpacking PBX Equipment

**4.01** Unpack the PBX at a point as near the final location as possible.

### B. Placing PBX

**4.02** Select the PBX module containing the power equipment, located in slide 1, and place in position. Place module 2 adjacent to and to the right of module 1. See Fig. 1 and 2.

**4.03** When a power plant with battery reserve is provided, transfer end panel from module 1 to left side of battery module and place the battery module to the left of module 1. See Fig. 1 and 2.

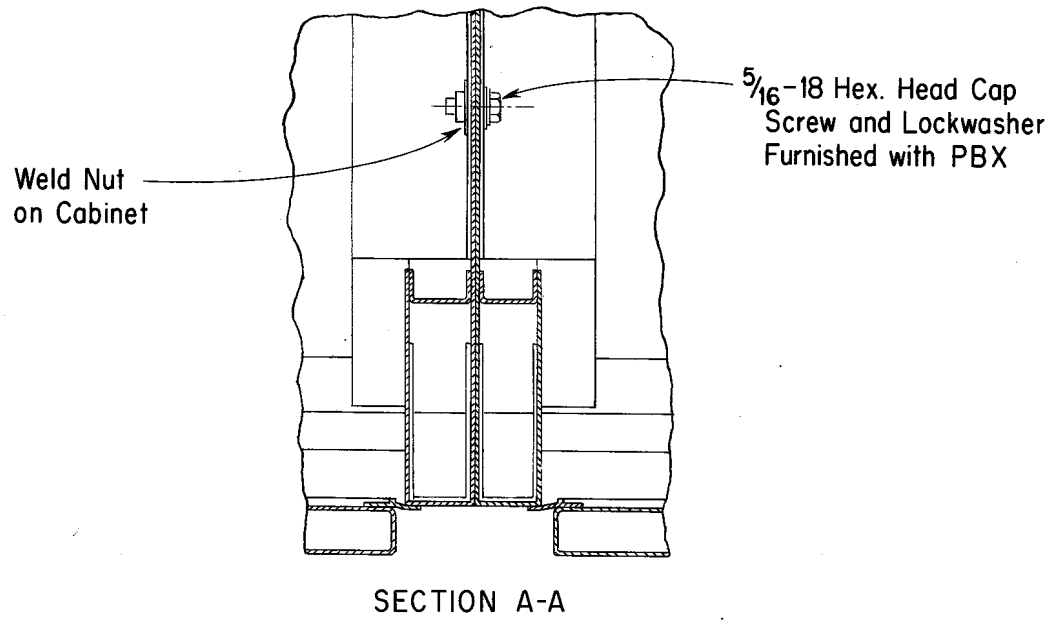
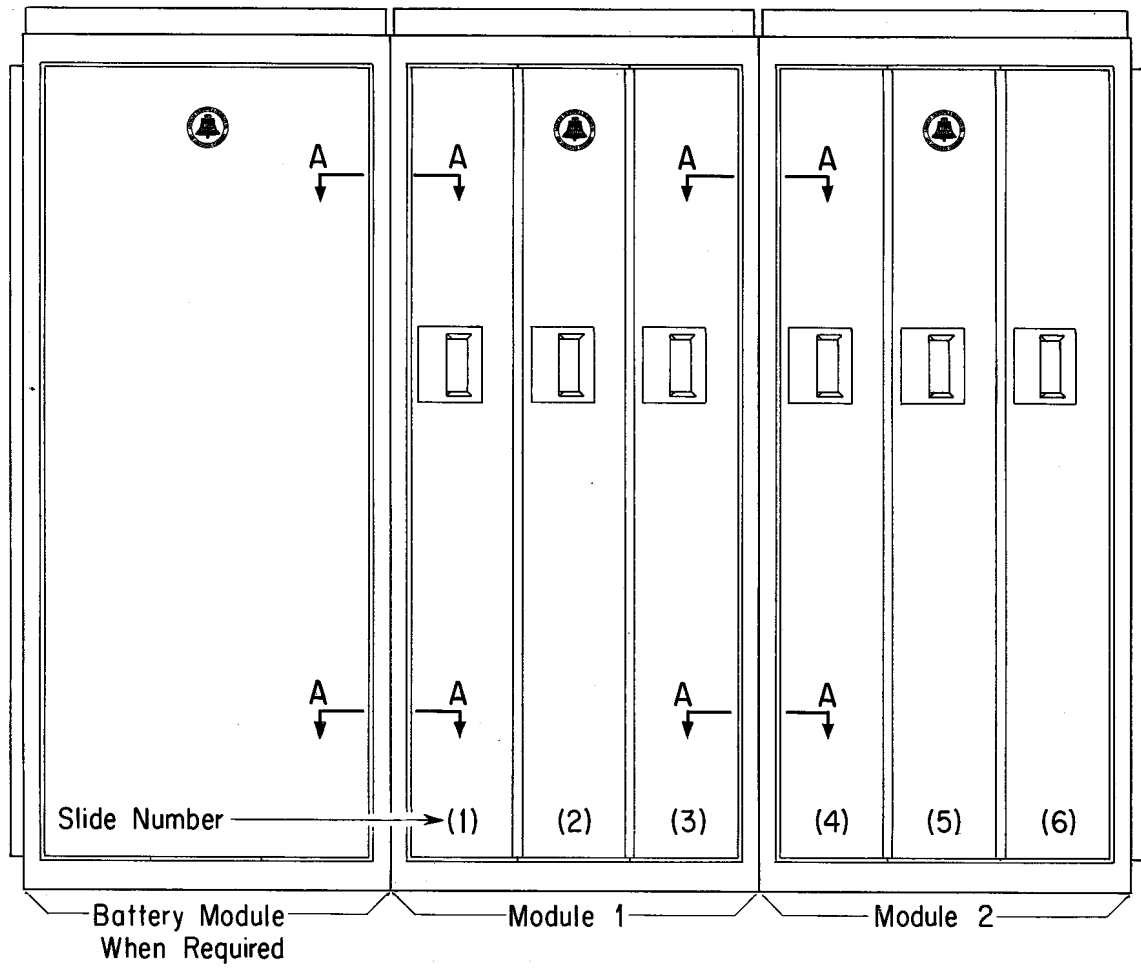

Fig. 2 — Alignment of 756A PBX Modules

## SECTION B556.201

**4.04** Level and align the modules. If necessary, shim the base of each module with small strips of hardwood. A sufficient number of shims should be used to insure equal distribution of weight at the base of the modules.

**4.05** To prevent damage in shipping, a 2-inch wide "L" shaped bracket is attached at the top front end of the supporting framework of each slide. *These brackets must be removed before the slides can be opened.* To disengage a bracket, open the top cover of the PBX module and remove the 19/32-inch hexagon nut holding the bracket. See Fig. 3. If the bracket remains fixed after removal of the nut, a slight inward push applied to the front of the slide will generally release the pressure, allowing removal of the bracket. *Avoid dropping bracket inside the equipment.*

**4.06** To open the slides of a module, the concealed latch in the top of the flush handle must be held operated as the slide is pulled out.

Only one slide of a module can be opened at one time.

**4.07** Open slides 3 and 4 and locate holes in the sides of each module which are provided for bolting the modules together. These holes are located at the top and bottom and near the front of the modules. See Fig. 2 (A-A). If the modules have been aligned properly (see 4.04) these holes should also be in alignment.

**4.08** Bolt the PBX modules together, using the two 5/16-inch No. 18 cap screws and washers furnished for this purpose, and close slides 3 and 4. *Caution must be exercised in placing and tightening these bolts in order to avoid injury to the hands and forearm.*

*Caution: The PBX modules must be bolted together and grounded (see 4.36 and 4.37) before power is connected to the PBX.*

**4.09** When the battery module is provided, open slide 1, remove snap-on cover from front of battery module, and bolt the modules together.

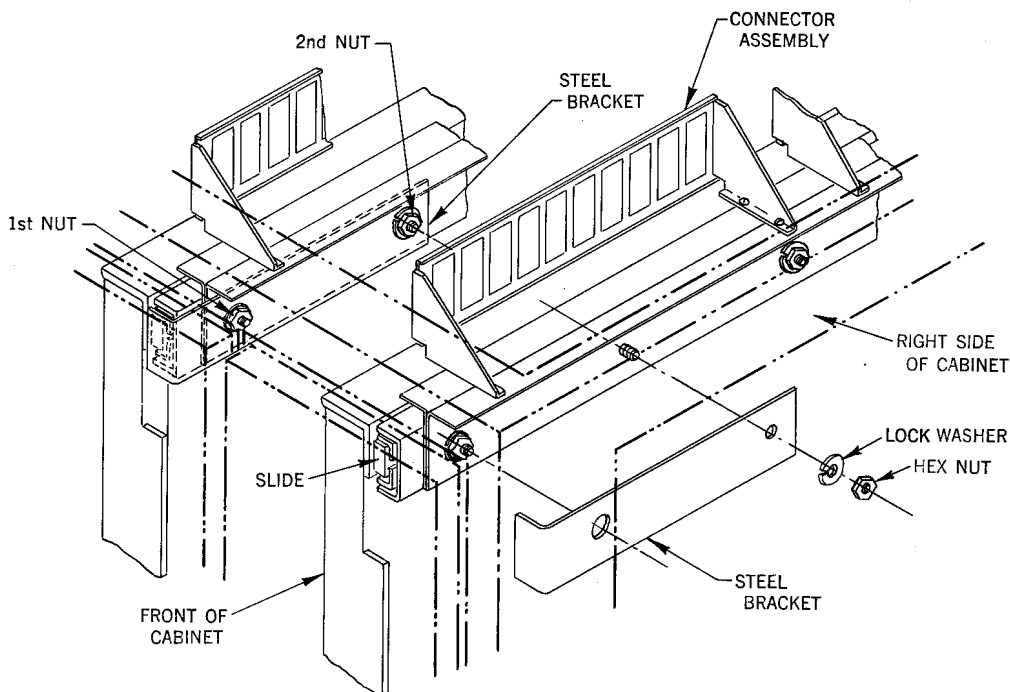

**Fig. 3 — View of Module with Raised Cover Showing "L" Shaped Bracket at Top Front of Slide**

**C. Placing Cross-Connecting Terminals**

**4.10** The arrangement of the cross-connecting terminal will depend on the type and number of attendant equipment and the type of connecting facilities used. The number of pairs in the cables from the various types of equipment are shown in Table A.

TABLE A — CABLE PAIRS FROM EQUIPMENT			
TYPE OF EQUIPMENT		CABLE PAIRS	NOTE
PBX	Module 1	75	1
	Module 2	100	1
Attendant Equipment	600-Type	100	2
	700-Type	50	1
	6-Button Key Telephone Set	25	3
	556A	Trunk and Misc	50
Station Line		100	4

**Note 1:** Plug-in cables, 30 feet, with one end stub ended are provided.

**Note 2:** Unit equipped with 8-foot mounting cord with plug-in connectors on each end. Connecting plug-in cords, 50 and 100 feet, are provided.

**Note 3:** Cables furnished locally.

**Note 4:** Cables 100 feet in length are provided with PBX. 100-pair cable is plug-in type.

**4.11** If the equipment cables are not of sufficient length to reach the cross-connecting terminal, they should be spliced to additional lengths of cable. When binding post chambers are used, the cable stubs from the chambers may be spliced to the equipment cables.

**4.12** Typical arrangement of binding post chambers and connecting blocks are shown in Fig. 4 and 5.

**4.13** Mount the cross-connecting terminal in the location selected. Consideration should be given to future expansion of the service.

**4.14** Place the binding post chambers or connecting blocks and adapters in the terminal box according to the Bell System Practices applicable.

**D. Placing Attendant Equipment**

**4.15** Locate the attendant equipment in accordance with the customer's wishes and job instructions. If a 556A PBX is to be provided, refer to Sections B523.211 and B523.601.

**CABLE TERMINAL**  
(Equipped with binding post chambers and connecting blocks)

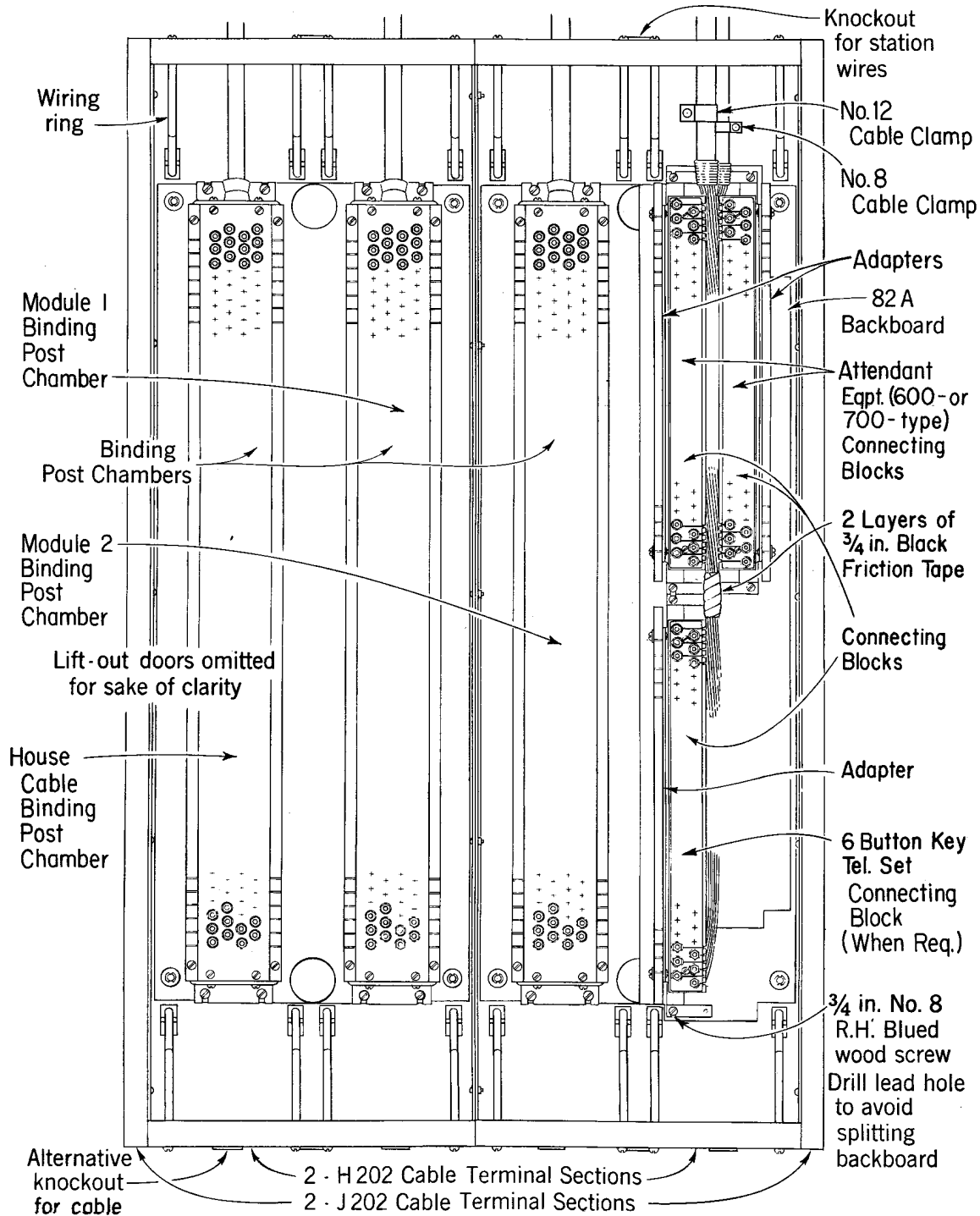

Note : Use of Binding Post Chambers is optional. Cables may be terminated on Connecting Blocks mounted on Adapters.

**Fig. 4 — Typical Arrangement in Cable Terminal**



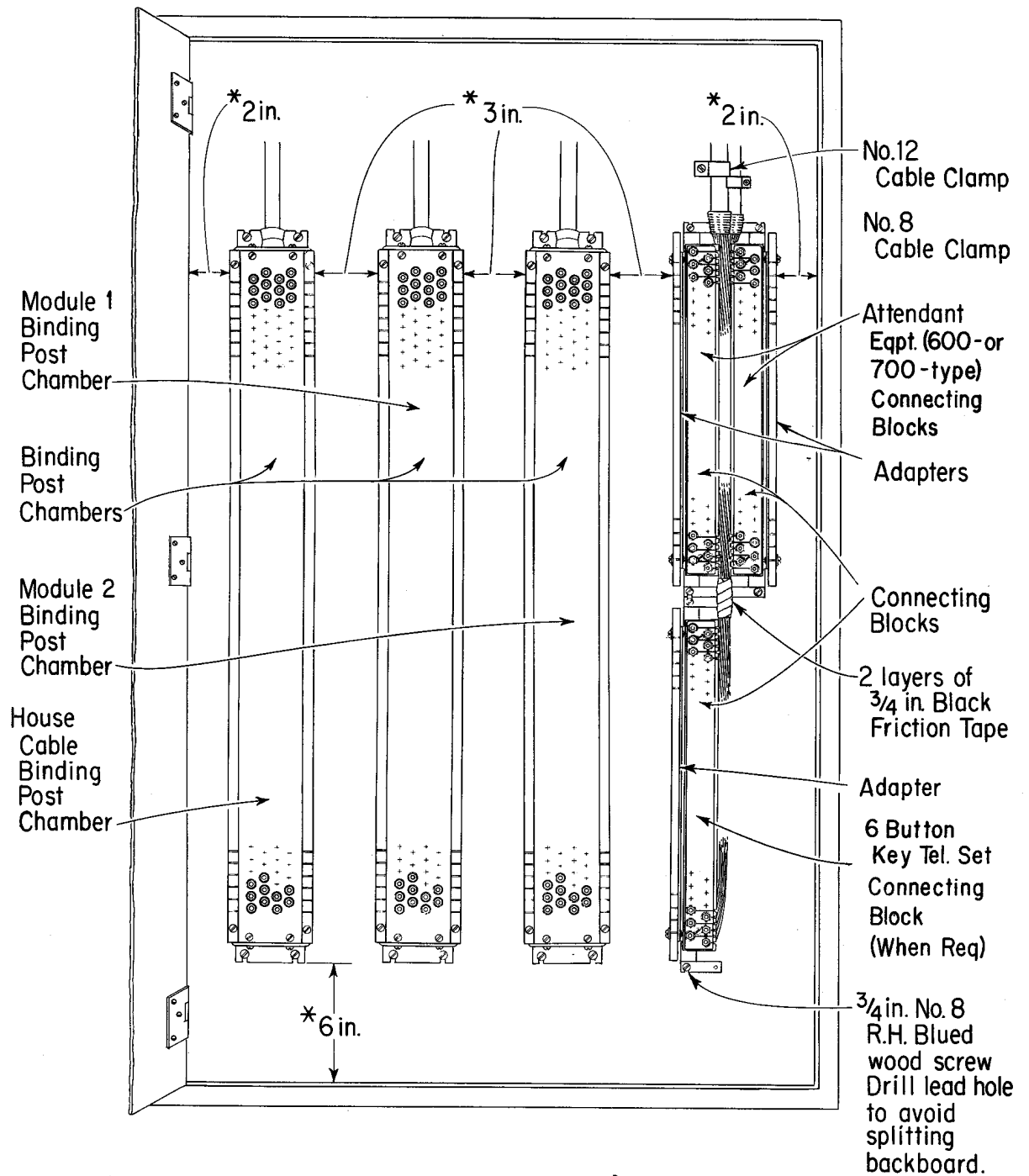

Note : Use of Binding Post Chambers is optional. Cables may be terminated on Connecting Blocks mounted on Adapters.

\* Minimum Dimensions

Fig. 5 — Typical Arrangement in Customer Furnished Terminal

**E. Cabling and Wiring**

**PBX to Cross-Connecting Terminal**

**4.16** If cable entrance to PBX modules is to be concealed, drill holes through wall or partition and feed cables through the holes leaving sufficient slack in cables to allow the plugs on the cables to be inserted in their respective sockets in the PBX.

**4.17** Prepare the PBX for crown and house cable installation. Raise the top cover of each module and engage the support brace in the slot in the side rail of the module.

**4.18** Place the PBX crown cable (interconnecting cable for modules 1 and 2) and dress plugs into proper position. Do not connect plugs until the cables in 4.19 through 4.21 have been placed into position. See Fig. 6.

**4.19** Place 75- and 100-pair house and feeder cables and dress plugs into proper position in modules 1 and 2. See Fig. 6.

*Note:* The house and feeder cables on older equipment were 76-pair and 101-pair cables.

**4.20** When a power plant with reserve batteries is provided, place the battery cable and dress plug into proper position in module 1. See Fig. 6.

**4.21** When a 556A PBX is provided as the attendant equipment, place the 50-pair supplementary house cable and dress the plugs into proper position in modules 1 and 2. See Fig. 6.

**4.22** Insert plugs of cables into their respective sockets exercising care not to damage pins or jacks of the plug and socket assembly.

**4.23** Secure house and feeder cables to PBX modules by cable clips furnished with PBX and tie to crown cables as shown in Fig. 6. Additional ties to the crown cable may be provided as required to add support for house and feeder cables.

**4.24** Run and fasten the house and feeder cables to the cross-connecting terminal box and terminate on binding post chambers or connecting blocks as shown in Fig. 7.

**Attendant Equipment to Cross-Connecting Terminal**

**4.25** Run and fasten the cable from the various types of attendant equipment and connect to binding post chambers or connecting blocks as described in 4.26 through 4.32.

**4.26** *700-Type Attendant Equipment:* Terminate cable on a binding post chamber as shown in Fig. 8 or on connecting blocks as shown in Fig. 9.

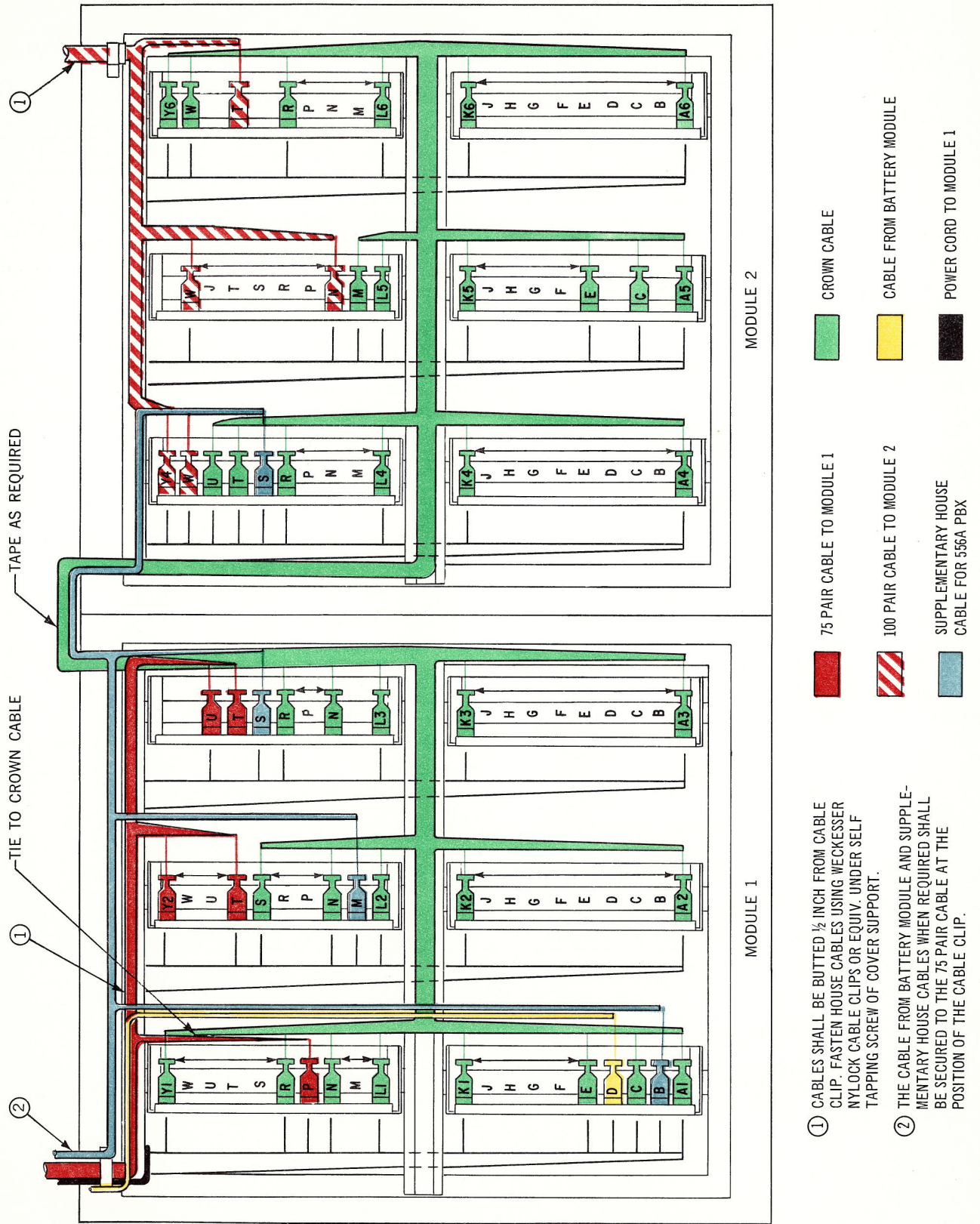

- ① CABLES SHALL BE BUTTED 1/2 INCH FROM CABLE CLIP. FASTEN HOUSE CABLES USING WECKER'S NYLOCK CABLE CLIPS OR EQUIV. UNDER SELF TAPPING SCREW OF COVER SUPPORT.
- ② THE CABLE FROM BATTERY MODULE AND SUPPLEMENTARY HOUSE CABLES WHEN REQUIRED SHALL BE SECURED TO THE 75 PAIR CABLE AT THE POSITION OF THE CABLE CLIP.

Fig. 6 — Placement of Cables in 756A PBX

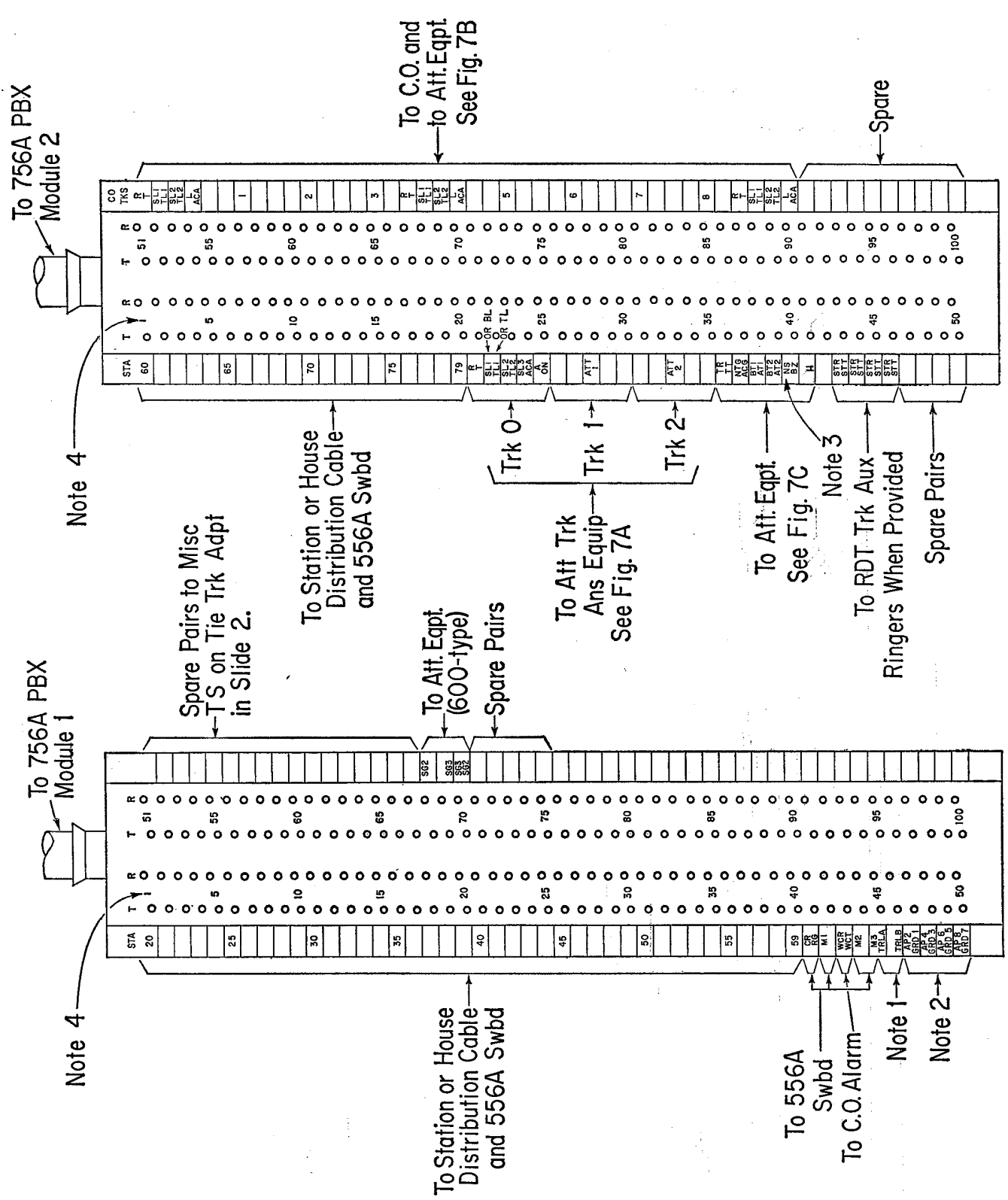

Fig. 7 – Typical Arrangement for Termination of 756A House and Feeder Cables

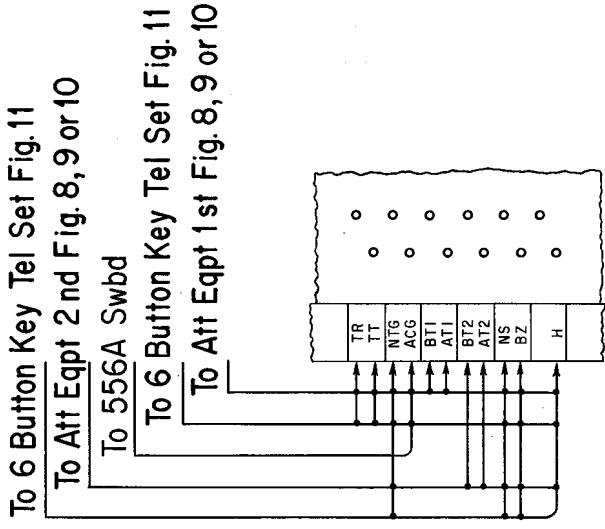

Fig. 7A

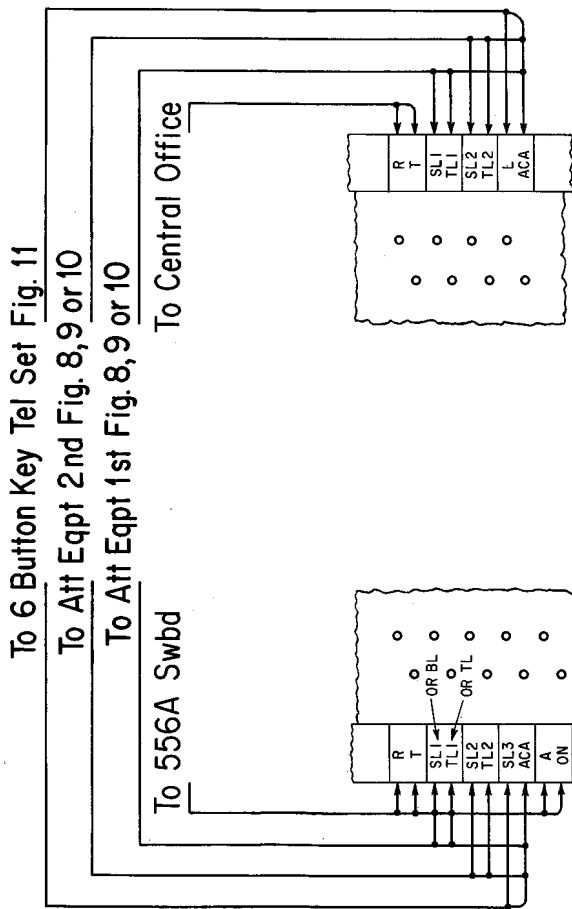

Fig. 7B

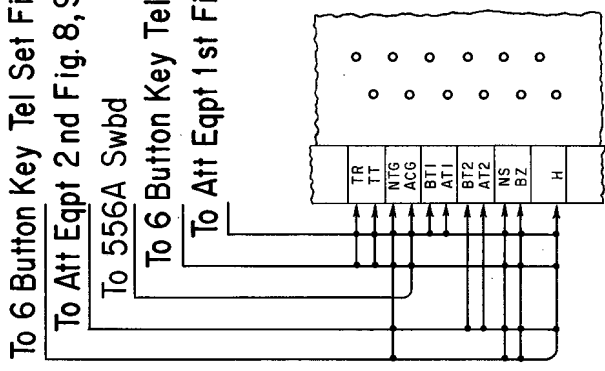
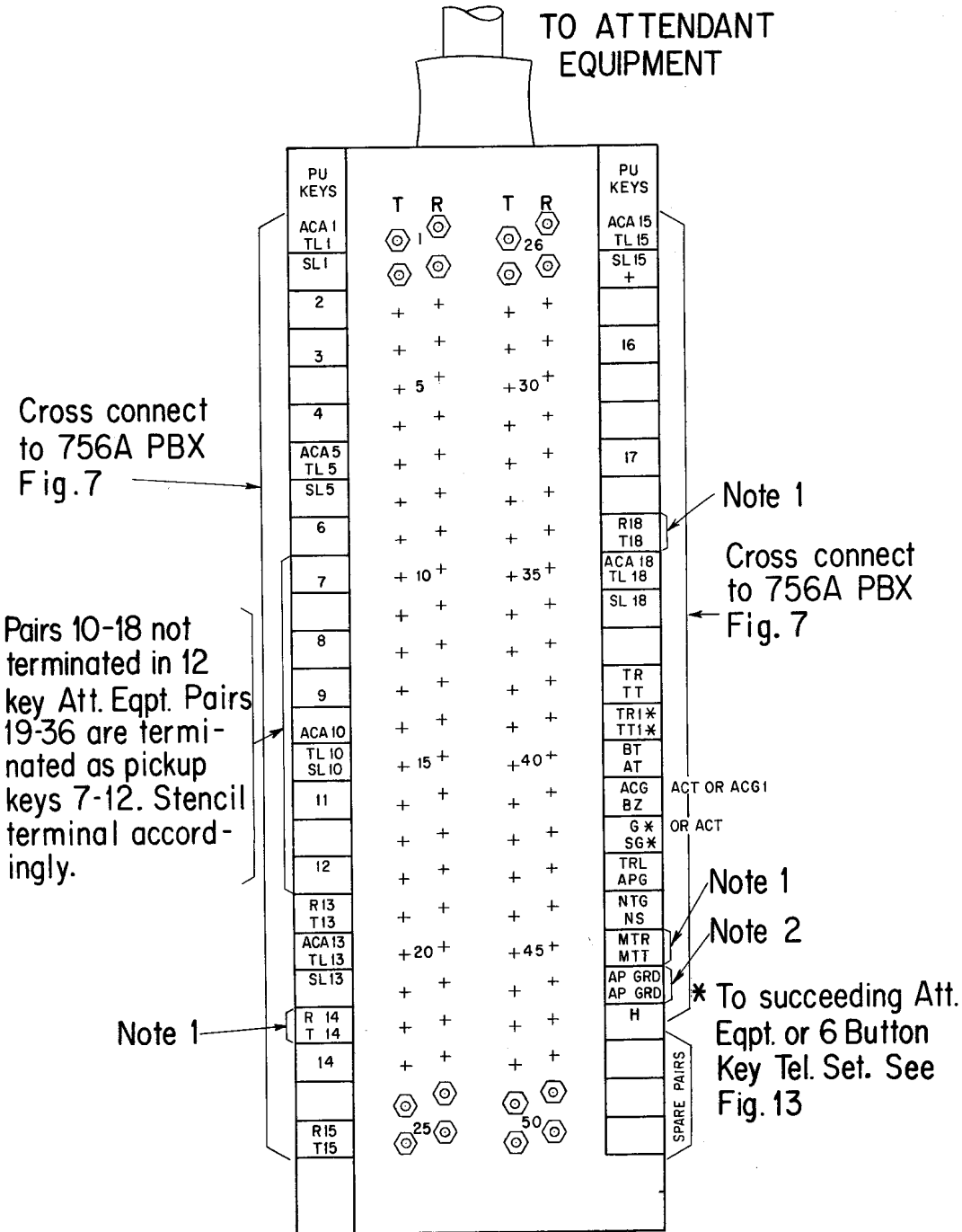

Fig. 7C

Fig. 7 - Continued

- Note 1:** Refer to SD-65743-01 or SD-65746-01 for options for cross-connecting to TRL leads of Att Eqpt, Fig. 8 or 9.
- Note 2:** Strap AP GRD 1-8 together and run a wire (18 GA MIN) to an approved local ground.
- Note 3:** Connect NS lead to AP GRD when Night Service Key is not required.
- Note 4:** Pair Numbers are not to be stamped.



- Note: 1 Cross-connect T and R of pickup keys 14 -18 to MTT and MTR leads when keys are used for trunks or to station line circuit Fig. 7 when keys are used for station line pickups.  
 2 Connect for 1st Att. Eqpt. only.  
 3 Pair numbers shown on terminal block not to be stamped

**Fig. 8 — Typical Arrangement for Termination of Attendant Equipment (700-type) Using Binding Post Chambers (Stenciling shown for 18 keys)**

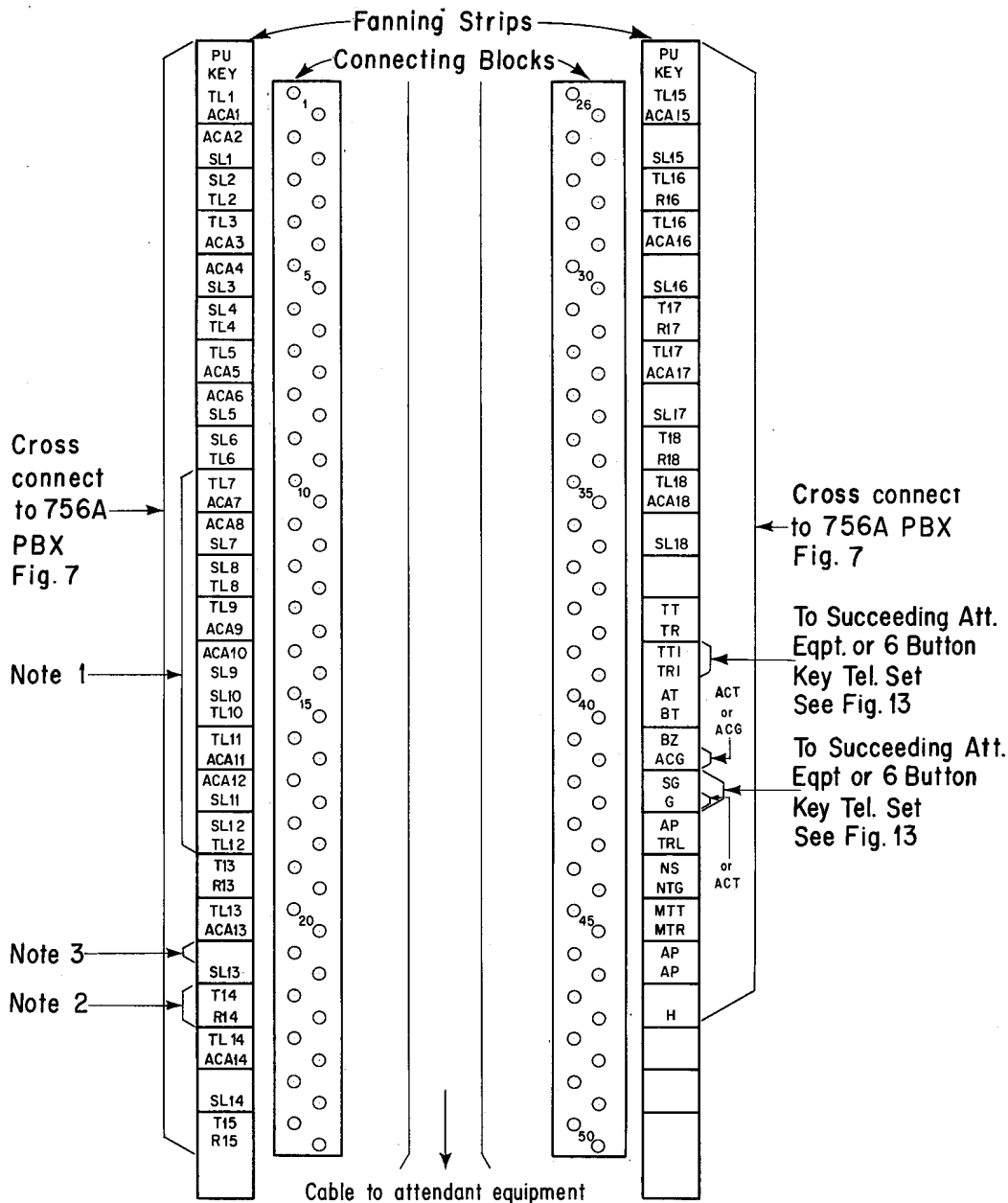

Note 1-Pairs 10-18 not terminated in 12 key Att. Eqpt. Pairs 19-36 are terminated as pickup keys 7-12. Stencil terminal accordingly.

Note 2-Cross connect T & R of pickup keys 14-18 to MTT and MTR leads when keys are used for trunks or to station line circuit Fig. 7 when keys are used for station line pickups.

Note 3-Conductors terminated on tip binding post of pairs 21,24,27,30,33,36 and 47 are spare. Conductors terminated on pairs 37,48,49 and 50 are spare.

Note 4-Pair numbers shown on connecting block not to be stamped.

**Fig. 9 — Typical Arrangement for Termination of Attendant Equipment (700-type) Using Connecting Blocks (Stenciling shown for 18 keys)**

4.27 **600-Type Attendant Equipment:** Terminate cable on a binding post chamber or on connecting blocks as shown in Fig. 10.

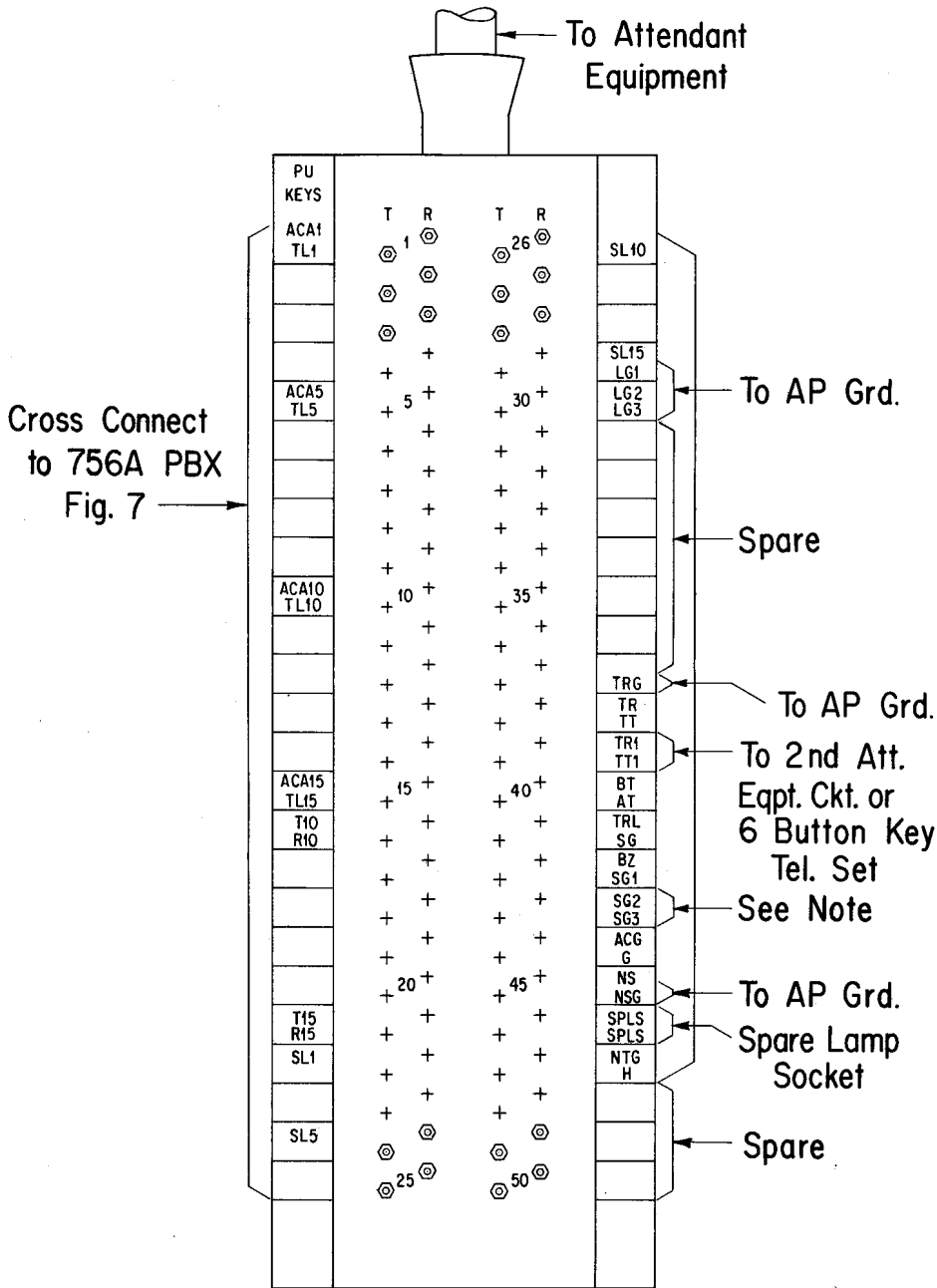

Note: When 600 - type set is used with cordless position circuit SD-65751-01, strap the SG2 and SG3 leads.

Fig. 10—Typical Arrangement for Termination of Attendant Equipment (600-type) Using Binding Post Chambers (Stenciling shown for 18 keys)



**4.28 6-Button Key Telephone Set:** Terminate cable as shown in Fig. 11.

The station cord conductors are terminated in the standard manner for the type of set used. *When a 6-button key telephone set is used as the attendant equipment,* a NIGHT key and a DIAL BACK key may be furnished. The keys are mounted externally and connected in accordance with the cordless position circuit drawing. The NS and AP leads are extended from the connecting blocks for the NIGHT key and the DB leads for the DIAL BACK key.



**4.29 556A PBX Used as Attendant Position:**

Run and fasten the supplementary plug-in cable from the 756A PBX to the cross-connecting terminal and terminate as shown in Fig. 12. Run

and fasten the cables from the 556A PBX to the cross-connecting terminals in accordance with Section B523.601.

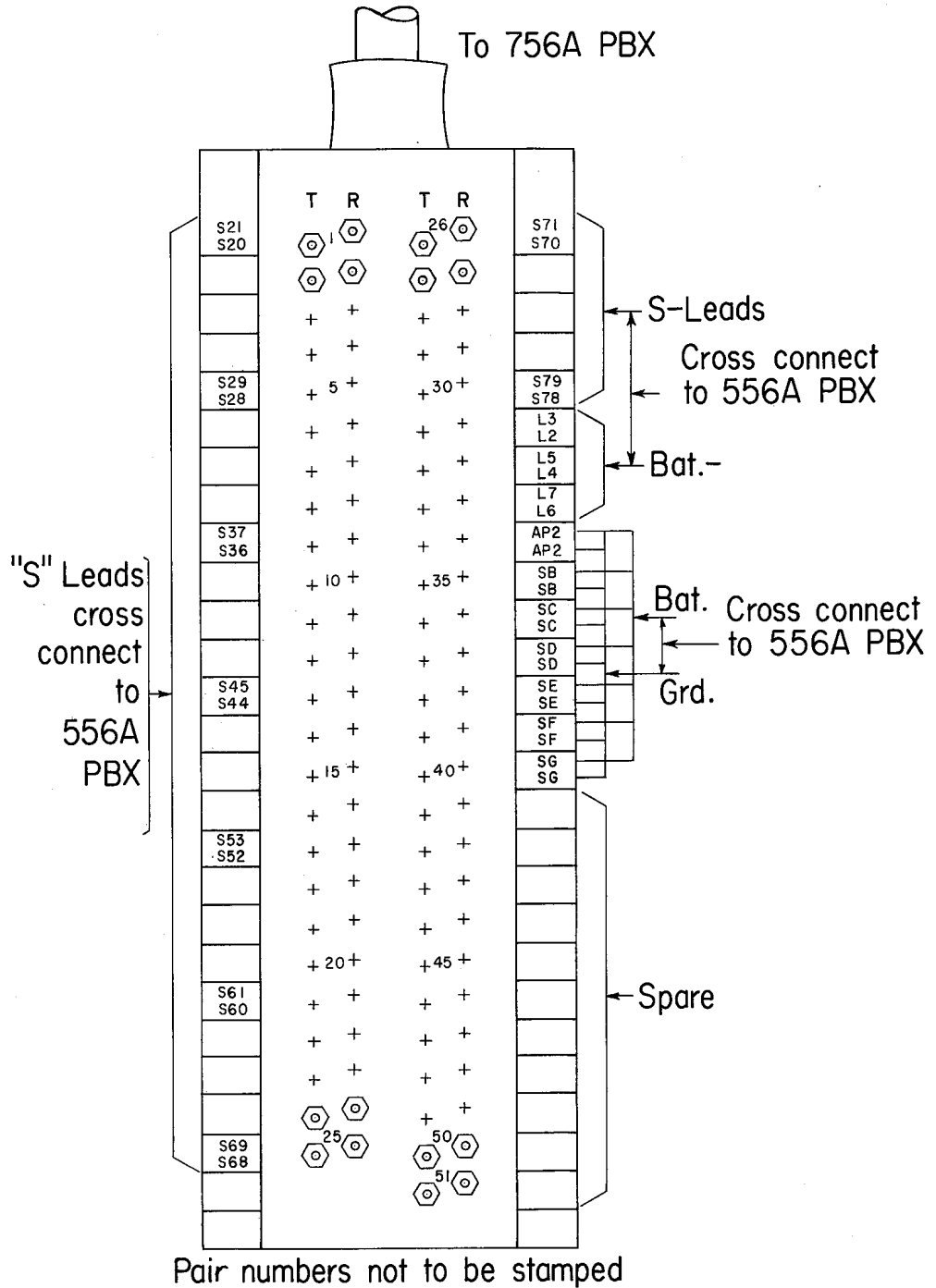

**Fig. 12—Typical Arrangement for Termination of Supplementary Cable from 756A PBX**

**Multiple Attendant Positions**

**4.30** When cordless attendant equipment (700- or 600-type) is used as the primary attendant position, one additional cordless position and/or one 6-button key telephone set may be provided.

**4.31** When a 556A cord-type switchboard is provided for the attendant equipment, a 600- or 700-type attendant equipment or 6-button key

telephone set may be used for auxiliary equipment.

**4.32** Typical arrangements, when multiple attendant answering is provided, are shown in Fig. 13.

**Lettering and Numbering**

**4.33** Letter and number the fanning strips of the binding post chambers and connecting

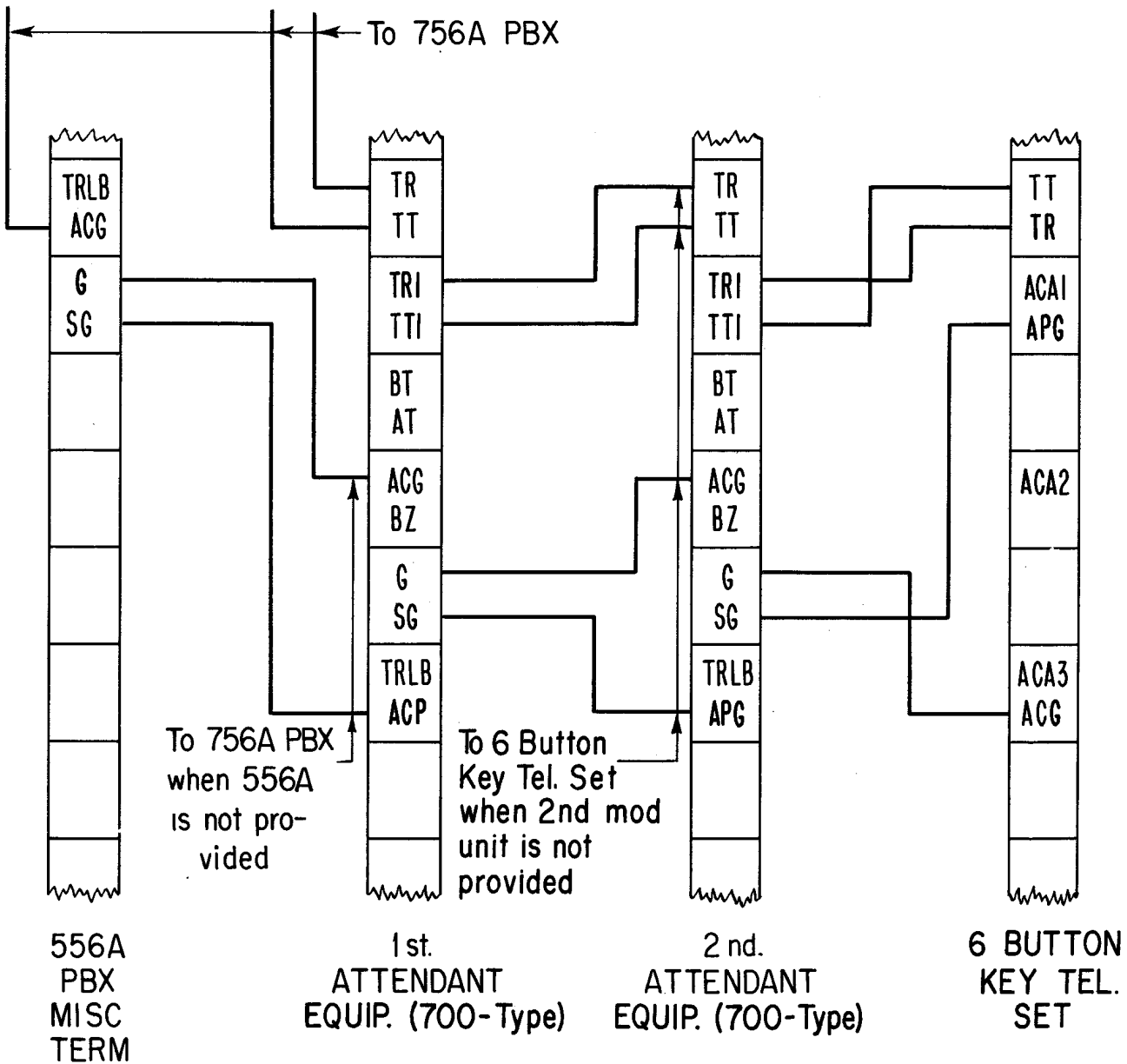

**Fig. 13 — Typical Arrangements for Cross-Connecting Position Circuit when Multiple Attendant Answering Is Provided**

blocks, as shown in Fig. 7, 8, 9, 10, 11, 12, and 13 using 1/8-inch and 3/16-inch rubber stamps, and in accordance with Section B502.605.

**4.34** Due to the number of characters necessary to designate leads and locations on fanning strips, care should be used in lettering and numbering of designations.

**4.35** If connecting blocks are used which have the tip binding post positioned above and to the left of the ring binding post when stenciling Fig. 7, 8, 10, 11, and 12, the designations for single leads should be transposed.

#### Grounding

**4.36** Ground for the PBX is normally furnished by the third wire in the power cord; however, to insure that the PBX modules remain grounded should the power cord be removed a local ground must be provided.

**4.37** Run and connect an 18-gauge (minimum) wire from "AP" ground terminals on 756A PBX binding post chamber to the nearest source of approved local ground.

#### F. Placing Batteries in Battery Module

**4.38** Precautions, such as the use of rubber gloves, rubber aprons, and goggles, which may be deemed necessary, shall be employed in the handling of batteries. A coating of petrolatum on the hands will give some measure of protection in the case of slight exposure to the electrolyte.

**Note:** Batteries are shipped containing electrolyte and fully charged.

**4.39** Remove battery jars and connectors from shipping case.

**4.40** Inspect each battery jar to see that the electrolyte is at proper height and that the white ball is at the top of the cage, which indicates a charged battery.

**4.41** Place the battery jars in the bottom of the battery cabinet arranged as shown in Fig. 14 with a clearance of 3/8 inch to 5/8 inch between batteries.

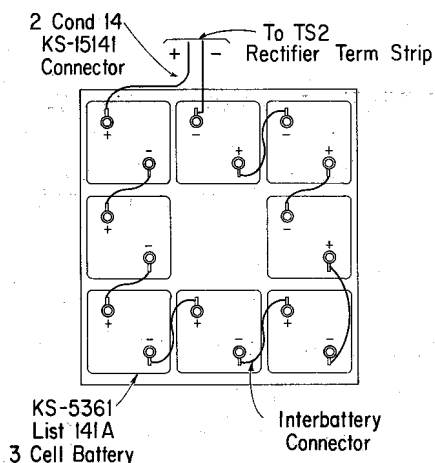

Fig. 14 — Battery Connections

**4.42** Connect the negative (-) terminal of a battery to the positive (+) terminal of another battery using one of the interbattery cable connectors. Connect the other batteries in the manner shown in Fig. 14.

**4.43** Connect the negative (-) lead of the two-conductor connector to the negative (-) terminal of an end battery and the positive (+) lead of the connector to the positive (+) terminal of the other end battery. See Fig. 14.

#### G. Station Equipment

**4.44** The 756A PBX is designed so that any standard station equipment or key equipment normally used in association with PBX service may be used with it.

**4.45** Run and fasten wire or cable, if needed, from cross-connecting terminal to station equipment and connect this equipment according to the Bell System Practices applicable.

**4.46** At stations arranged for automatic transfer to central office trunks in the event of a power failure, or for fixed night connections, install a dial tone START key (551A or equivalent) in accordance with the schematic drawing for the Alarm Transfer and Test Circuit. See 5.12. In order to bring in dial tone or the central office operator, this key has to be depressed until dial tone or central office operator is heard. It is then released in order that dialing or talking may proceed.

## SECTION B556.201

### H. Miscellaneous Equipment

#### 4.47 *Ringdown Tie Trunks (Plug-In Type):*

Four plug-in ringdown tie trunks may be provided in the place of four two-way central office trunks. These tie trunks are mounted in slide 5, mounting plate spaces G and H, K and L, T and U, W and X and use trunk equipment 3, 4, 8, and 9.

(a) The two-way central office trunk capacity of the PBX is reduced one for each plug-in ringdown tie trunk provided.

(b) When the plug-in ringdown tie trunks are provided the PBX dial pulse register must be wired to provide two-digit code 9 operation. See Table E.

#### 4.48 *Ringdown Tie Trunks for Use with 556A PBX:* Refer to Section B523.601 for installation of tie trunks.

**4.49 *Dial Repeating Tie Trunks:*** Either the two-way dial selected or the dial repeated incoming dial selected outgoing type of trunk may be used with the PBX. They may be mounted in slide 2, mounting plate spaces R to AB or in slide 3, mounting plate spaces W to AB, or externally.

(a) The tie trunks use the universal line circuits. The universal line circuits, as furnished, are arranged for station lines and are numbered 20 to 29. When arranged for use as trunk type circuits, they are numbered 80 to 89.

(b) The station line circuit capacity is reduced one line for each dial repeating tie trunk provided.

(c) When a dial repeating tie trunk is provided, the PBX dial pulse register must be wired to provide code 8 operation. See Table E.

**4.50 *Loudspeaker Paging Trunk:*** This equipment when provided, may be mounted in slide 2, mounting plate spaces R to AB or slide 3, mounting plate spaces W to AB, or externally.

(a) The paging trunk may be dial selected and/or it may appear on a line pick-up key of the attendant equipment.

(b) When the paging trunk is dial selected, it uses one of the universal line circuits, and the station line capacity of the PBX is reduced by one. See 4.49 (a).

(c) When a paging trunk is dial selected the PBX dial pulse register must be wired to provide code 8 operation. See Table E.

**4.51 *Recorded Telephone Dictation Trunk:*** Because of the large number of leads between the trunk equipment and dictating machine, the trunk equipment should be mounted outside of the PBX in approved apparatus mounting equipment.

(a) The dictation trunk uses one of the universal line circuits. See 4.49 (a).

(b) When the dictation trunk is provided, the station line capacity of the PBX is reduced by one.

(c) The PBX dial pulse register must be wired for code 8 operation. See Table E.

**4.52 *Code Call Unit:*** This unit may be mounted in slide 2, mounting plate spaces R to AB.

(a) The code call unit uses the universal line circuits.

(b) The capacity of the PBX is reduced by two station lines per code calling channel provided. The calling end of the channel is assigned a trunk code (80 to 89) and the answering end is assigned a station line number (20 to 29).

**4.53 *Dial Conference Circuit:*** This circuit may be mounted in slide 2, mounting plate space AA or AB or in slide 3, mounting plate spaces W to AB, or externally.

(a) The conference circuit uses the universal line circuits.

(b) The station line capacity of the PBX is reduced one line for each conference terminal provided. A maximum of five conference terminals may be provided.

(c) The conference circuit should be assigned to trunks 80 to 84, or 85 to 89.

(d) The PBX dial pulse register must be wired for code 8 operation. See Table E.

**4.54 *Long-Line Units:*** A variety of long-line units are available for use.

5. PLACING IN SERVICE

A. General

5.01 Placing the 756A PBX in service consists of starting and making initial adjustments of the power plant and placing wiring for the various features and options to be provided.

5.02 The information in this part pertaining to the various features and options supplements the information on the circuit drawings. If the required information or the specific arrangement needed is not shown, refer to the circuit drawings. The cabling diagrams (CAD) for the 756A PBX are shown on SD-65746-01.

5.03 The various features or options in most cases are provided by strapping at terminal strips. The wire wrapping tools provided with the PBX may be used for making and removing connections. Refer to Section B502.009 for method of using the tools.

B. Power Supply

5.04 Place the J86464 power plant in service as covered in Section B301.866.

*Caution: Follow the procedures in the order covered in the section. The power plant interrupter is shipped without oil in the gear train and must be filled with oil before operation.*

C. Station Lines

5.05 The options for station lines are provided by placing or removing strapping on the class-of-service terminal strips.

5.06 *Class-of-Service Terminal Strips (Line)* are located as follows:

- (a) Lines 20 to 39, slide 2 mounting plate M.
- (b) Lines 40 to 59, slide 3 mounting plate M.
- (c) Lines 60 to 79, slide 4 mounting plate M.

5.07 *Class-of-Service Options* available for station lines are shown in Table B and Fig. 15.

TABLE B — CLASS-OF-SERVICE OPTIONS FOR STATION LINES			
OPTIONS		STRAPS ON LINE T.S.	NOTES
Toll	Allowed	CS to TLA, S to S1 or S1A	1, 2, 6
	Denied	CS to TLD, S to S1 or S1A	3, 6
Restricted		S to S1 or S1A	4, 6
Unassigned		CS to TLA	5
Hunting	One-Way	See 5.08 (a)	
	Two-Way	See 5.08 (b)	

**Note 1:** PBX is furnished with all lines strapped for toll allowed service.

**Note 2:** Toll allowed lines have access to all equipped trunk codes.

**Note 3:** Toll denied service may only be provided where the central office is arranged for toll diverting.

**Note 4:** Restricted lines may be connected to the central office only by the attendant.

**Note 5:** Calls to unassigned lines are connected to an attendant trunk or busy tone trunk. The CS to TLA strap, if wired, need not be removed.

**Note 6:** On the class-of-service terminal strips for station lines 20 to 24 and 25 to 29, there is an S1A lead instead of an S1 lead as shown on the other station line class-of-service terminal strips. See Fig. 16.

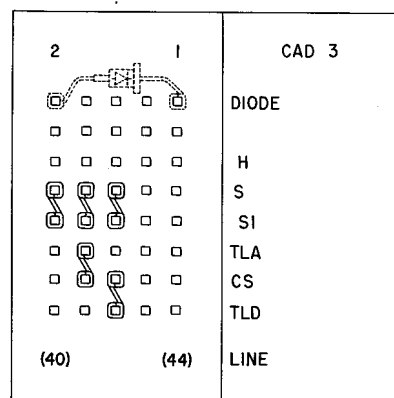

Examples

- Station 40 - Restricted
- Station 41 - Toll Allowed
- Station 42 - Toll Denied
- Stations 43-44 - Unassigned

**Fig. 15 — Typical Strapping on Class-of-Service Terminal Strip (Station Lines 40 to 44)**

5.08 **Hunting** for station lines may be arranged within each tens group. One-way and two-way hunting may be provided as follows:

(a) **One-Way Hunting** is arranged by the insertion of diodes between the H terminals of the class-of-service terminal strips of the station lines.

(1) The PBX is furnished with one diode per five station lines in the line groups 30 to 79. The diode is mounted on the back of the station line class-of-service terminal strip so that it may be connected between any two H terminals of station lines in that group. See Fig. 15.

(2) The diodes for station line group 20 to 29 are furnished in loose form with the PBX. They may be connected to the H terminals of the station lines in this or other groups as required. See Fig. 16.

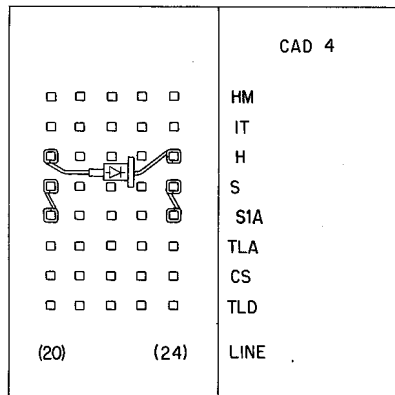

Stations 20 and 24 strapped for one direction hunting  
Station 20 hunts to station 24.

Fig. 16 — Typical Strapping on Class-of-Service Terminal Strip (Station Lines 20 to 24)

(3) To provide one-way hunting between any two station lines in a group, connect a diode between the H punchings on the class-of-service terminal strip that is associated with these lines. The direction of hunting will be in the direction the arrow on the diode is pointing. See Fig. 17. The order of hunting may be reversed by reversing the diode connections.

(4) As many as five station lines may be grouped for one-way hunting.

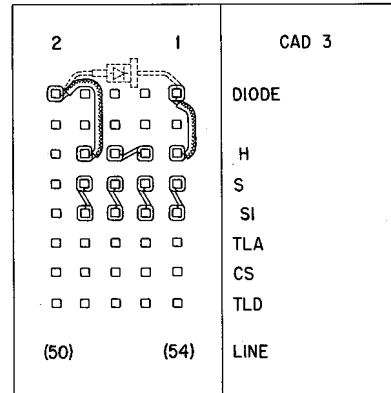

Examples

Station 51 hunts to station 54  
Stations 51 and 54 strapped for one direction hunting  
Stations 52 and 53 strapped for two direction hunting

Fig. 17 — Typical Strapping on Class-of-Service Terminal Strip Showing Straps for Station Hunting

**Note:** In earlier PBX, in which the KS-15724, L2 (GE-1N92) diode was furnished, only two station lines should be grouped in a chain for one-way hunting.

(b) **Two-Way Hunting** is provided by the insertion of straps between the H terminals on the class-of-service terminal strips of the station lines. See Fig. 18.

(1) As many as ten station lines may be grouped in a chain for two-way hunting in a tens group.

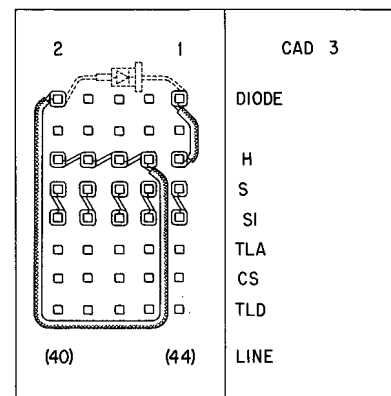

Examples

Stations 40,41,42,43, and 44 strapped for one and two direction hunting  
Stations 40,41,42, and 43 are two direction and can hunt to station 44 but station 44 cannot hunt to stations 40,41,42 and 43.

Fig. 18 — Typical Strapping on Class-of-Service Terminal Strips Showing Combination Hunting



TABLE C — TRUNK EQUIPMENT LOCATIONS			
P E R M A N E N T	NO.	SLIDE — 5	
		MTG PLATE	TS
P E R M A N E N T	0	A, B	B
	1	C, D	D
	2	E, F	F
	5	M, N	N
	6	P, Q	Q
	7	R, S	S
	P L U G - I N	3	G, H
4		K, L	L
8		T, U	U
9		W, X	X

(2) There are many combinations in which stations in a group can be connected together for one- or two-way hunting or both. A typical example is shown in Fig. 18.

#### D. Two-Way Central Office Trunks

**5.09** The PBX is furnished with six permanently wired two-way central office trunks. Space is provided for four additional plug-in trunks. The trunk equipment location is shown in Table C.

**5.10** Options for trunks are provided by placing straps on the central office trunk terminal strip located as shown in Table C and the central office trunk hunting terminal strip (CO TRK HUNT) located in slide 4 on mounting Z. See Table D.

TABLE D — TRUNK OPTIONS						
OPTION		STRAPS ON CO TRK TS	STRAPS ON CO TRK HUNT TS	NOTES	FIG.	
Central Office Nominal Talking Battery Voltage	40V or More 39V or Less	16 to 26 26 to 27	— —	1 —	— 19	
One-Way or Unassigned	All Types	Remove 18 to 28 Place 17 to 18	— —	2 —	19 —	
	<i>Plug-in</i> Two-Way CO or R.D. Tie Trunks	—	Trk 3, 16 to 17	3	—	
		—	Trk 4, 17 to 18	3	—	
		—	Trk 8, 27 to 28	—	—	
—		Trk 9, 26 to 27	—	—		
Attendant Service	Lockout	Yes	—	4	—	
		No	21 to 22	5	19	
	Secrecy	Yes	15 to 25	—	—	19
		No	—	—	6	—
	Restricted	Yes	12 to 13	—	7	19
		No	13 to 23	—	8	19
Hunting		See 5.11	—	—	20	
Automatic Transfer		See 5.12	—	—	—	

**Note 1:** Strap 16 to 26 furnished with PBX.

**Note 2:** Strap 18 to 28 furnished with PBX. Remove this strap when two-way central office trunk is unassigned or assigned and used for one-way incoming service only.

**Note 3:** These straps are furnished with the PBX. As each plug-in trunk is assigned, remove the strap associated with the trunk equipment used.

**Note 4:** Lockout service prevents attendant from re-entering a central office connection except on a recall signal or before the called station answers.

**Note 5:** Strap 21 to 22 furnished with the PBX. Nonlockout allows the attendant to re-enter incoming calls at all times, but the attendant cannot enter dial selected outgoing calls. This option is furnished with PBX.

**Note 6:** When secrecy attendant service is provided and the attendant re-enters a call, the attendant can only converse with the called station.

**Note 7:** Restricted attendant service prevents the attendant from making outgoing central office calls.

**Note 8:** Strap 13 to 23 furnished with PBX.

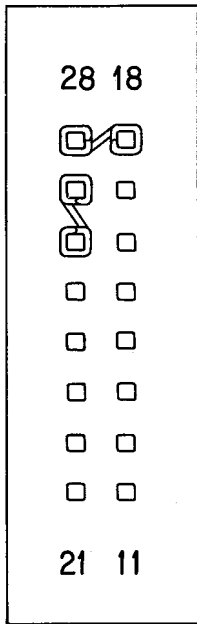

Nominal C.O. Battery  
Voltage of 39V  
or Less

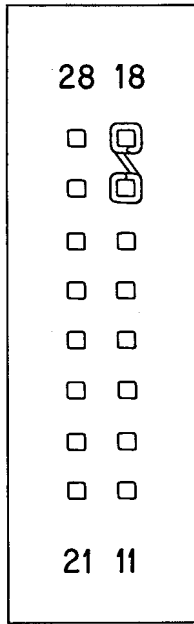

One - Way  
or  
Unassigned

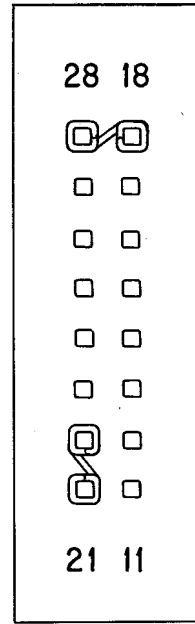

Nonlockout

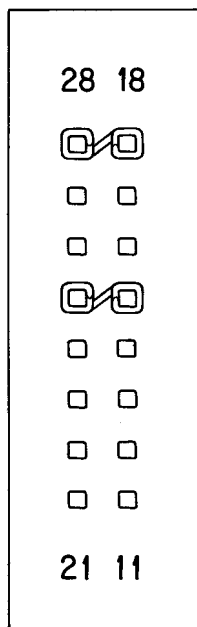

Secrecy

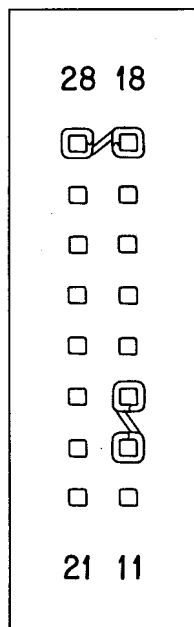

Restricted

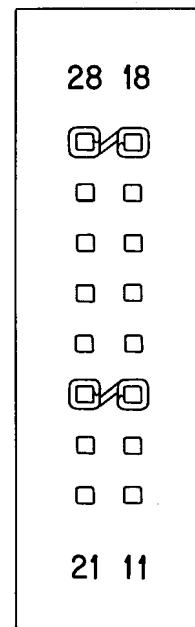

Nonrestricted

Fig. 19 — Typical Strapping on Central Office  
Trunk Unit Terminal Strip

**5.11 Trunk hunting** is provided by strapping together the H terminals on the central office trunk-hunting terminal strip (CO TRK HUNT). The PBX is furnished with all ten H terminals of the central office trunks strapped together.

- (1) If one hunting group of 10 or less central office trunks are to be provided, using the single digit code 9, the strapping as furnished should not be changed.
- (2) If two or more hunting groups are provided, the strapping must be rearranged at the central office trunk-hunting terminal strip and in the dial pulse register. See Table E.
- (3) A typical example of strapping for trunk hunting is shown in Fig. 20.

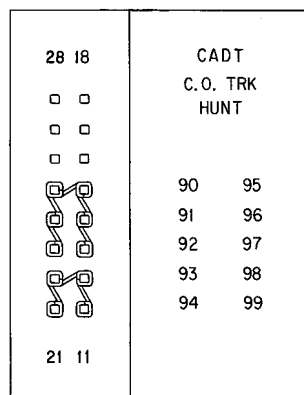

Example

Hunting on Trunk Group 0, 1, 2, 5, 6 and 7  
 Hunting on Trunk Group 3, 4, 8 and 9

**Fig. 20—Typical Strapping on Central Office Trunk-Hunting Terminal Strip Showing Strapping for Trunk Hunting**

**5.12 Automatic Transfer:** In the event of a power failure, all relays in the PBX release and either 3 or 4 central office trunks are automatically transferred to stations. In a PBX equipped with flexible night connections, trunks 0, 1, and 2 are connected to stations 30, 31, and 32, and in one equipped with fixed night connections the trunks 0, 1, 2, and 5 are connected to stations 30, 31, 32, and 33.

### E. Attendant Trunks

**5.13** The PBX is furnished with three attendant trunk units located in slide 5 on mounting plates Y, Z, and AA. They are wired for operation of the PBX with a cordless attendant position or cord switchboard.

**5.14** If the PBX is to be operated without an attendant, the following wiring changes must be made.

- (1) Place straps between terminals 13 and 23, and 16 and 26 on the terminal strip on the attendant trunk units 0, 1, and 2 in slide 5.
- (2) Remove straps between terminals 11 and 21, 12 and 22, 15 and 25, and 17 and 22 on the terminal strip on the attendant trunk units 0, 1, and 2 in slide 5.

### F. Tie Trunks

**5.15 The ringdown tie trunks** assigned to trunk equipments 3, 4, 8, and 9 should be arranged to form their own hunting group on the central office trunk-hunting terminal strip. See Fig. 20.

**5.16 The dial repeating tie trunks** assigned to the universal line circuits have the same classes of service available as station lines. Provide the classes of service required at the TS (A) on the tie trunk adapter unit in slide 2 or 3 in accordance with the circuit drawings.

### G. Dial Pulse Register

**5.17** The PBX is furnished with two dial pulse registers located in mounting plate spaces A to C, and D to F in slide 6.

**5.18** The dial pulse register must be arranged, by means of strapping on the dial pulse register terminal strip (DP REG 0 and DP REG 1), to receive originating class-of-service and/or class-of-call information as shown in Table E.

TABLE E — CLASS-OF-SERVICE OPTIONS — DIAL PULSE REGISTER

		FEATURE OR OPTION		STRAPS ON DP REG TS	NOTES
C L A S S O F  S E R V I C E	Trunk Code 8	Tens Digit 6 & 7 Intercepted (40 Line PBX)		11 to 21, 12 to 22	1
		Code 8 Intercepted (Not Equipped)		13 to 23, 23 to 24	1, 2
		Restricted Station or Dial Repeating Tie Trunks	Denied access to Code 8 and is intercepted	13 to 14, 15 to 25, 23 to 24	
			Provide access to Code 8	13 to 14, 15 to 25, 24 to 25	
	Trunk Codes 8 & 9	CO Trunk or Ringdown Tie Trunk	Not restricted for Codes 8 & 9 (not inter- cepted)	18 to 28	1, 2
			Restricted for Codes 8 & 9 (intercepted)	Remove 18 to 28	
		Code 9	One-digit	16 to 26	1, 2
			Two-digit	17 to 27	

**Note 1:** Straps furnished on 40-line PBX.

**Note 2:** Straps furnished on 60-line PBX.

#### H. Central Office Alarm

**5.19** If the PBX alarms are to be extended to the central office, strapping must be placed on the terminal strip on the fuse panel alarm and register unit located in slide 1, mounting plate W.

- (a) To arrange the alarm circuit to function with a marginal alarm system at the central office, strap terminals 47 and 48.
- (b) To arrange the alarm circuit to function with reverse battery alarm system at the central office, strap terminals 37 and 38.

#### I. Night Connections

**5.20** Two arrangements to provide night connections for the 756A PBX have been provided.

(a) **Fixed Night Connections (Manufacture Discontinued):** This arrangement provided for the transfer of four trunks to stations 30, 31, 32, and 33. These are the same stations used for automatic transfer. See 4.46 and 5.12. This arrangement can be modified locally in accordance with circuit drawing to provide flexible night connections.

(b) **Flexible Night Connections:** This arrangement permits the attendant to establish night connections between any central office trunk and any station.

#### J. Traffic and Trouble Registers

**5.21** The PBX is furnished with six registers located in slide 1 to be cross-connected as required to record traffic or troubles.

**5.22** The registers may be cross-connected by placing straps between terminals on register terminal strip. See Fig. 21.

6. FINAL TESTS AND INSPECTIONS

6.01 Tests and inspections required in connection with the installation work as covered in B556.202 shall be made before turning equipment over to the customer for use.

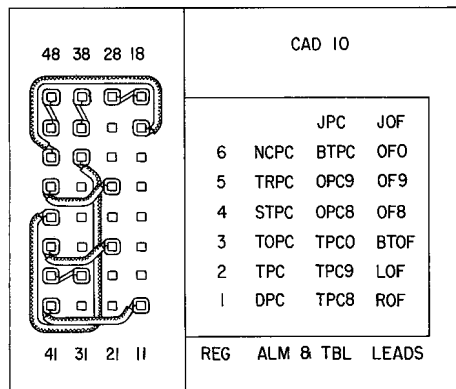

Example

Terminal	Reg	Lead Desig	Function
41-11	1	ROF	Dial Pulse Reg. Overflow
42-32	2	TPC	Terminating Peg Count
43-23	3	TPCO	TRK GRP 0 Terminating Peg Count
44-36	4	NCPC	No Connection Peg Count
45-25	5	OPC9	TRK GRP 9 Originating Peg Count
46-17	6	JOF	Junctor Overflow
47-48			Marginal Alarm
37-38			Battery Reverse Alarm
18-28			

Fig. 21 — Typical Strapping on Alarm and Register Unit Terminal Strip